

深圳市弗瑞鑫电子有限公司

规格承认书

2

22

—

prepare	<input type="checkbox"/>					
check						
approve				<input type="checkbox"/>	2	2



TRX电容一级代理商

深圳市弗瑞鑫电子有限公司

Add:深圳市宝安区西乡大道302号金源商务大厦B座3楼

Tel:0755-29563634

Fax:0755-27447020

SMD- 2

SMD 2 . .

/N

-3-082

/D

2021-11-15

/E

A1

/P

P 3 18

 TRX 专注电容器廿年	SMD- 2			
	SMD 2 . .			
	/N	-3-082	/D	2021-11-15
	/E	A1	/P	P 4 18

/CON EN

1.	P	N	-----	5
2.	P		-----	5-6
3.	D		-----	6
4.	C		-----	7
5.	P		-----	7-8
6.			-----	8-9
7.	P		-----	9-14
8.	C		-----	14
9.	C		-----	15
10.			-----	15
11.	P	P	-----	16-17
12.	A		-----	18

	SMD- 2 SMD 2 . .			
	/N	-3-082	/D	2021-11-15
	/E	A1	/P	P 5 18

1. /P N

T B 2 102 M E
 ① ② ③ ④ ⑤ ⑥

N . C

E

①

L

 TRX 专注电容器廿年	SMD- 2			
	SMD 2 . .			
	/N	-3-082	/D	2021-11-15
/E	A1	/P	P 6 18	

/E	
	/ /
L	MD- 2 MD- 2
E	/ D L / B(5P) / E(5) / F(3)
102	/ C (22-2200 F : 220-222)
M	/ C K(± 10%) / M(± 20%)
1 4408	1 1
2 3008	2 2
M0512	D

3. /D

		2020	M	1	01	1	01	16	16
		2021	N	2	02	2	02	17	17
2010	A	2022	P	3	03	3	03	18	18
2011	B	2023		4	04	4	04	19	19
2012	C	2024		5	05	5	05	20	20
2013	D	2025		6	06	6	06	21	21
2014	E	2026		7	07	7	07	22	22
2015	F	2027	8	8	08	8	08	23	23
2016	H	2028		9	09	9	09	24	24
2017	J	2029		10	10	10	10	25	25
2018	K			11	11	11	11	26	26
2019	L			12	12	12	12	27	27
						13	13	28	28
						14	14	29	29
						15	15	30	30
								31	31

20

N :

20

-

.

 TRX 专注电容器廿年	SMD- 2			
	SMD 2 . .			
	/N	-3-082	/D	2021-11-15
/E	A1	/P	P 7 18	

4. /C

C		C	C
L/C L	L/C A 60384-14	E315719	AC3008 (. . .)
C C	GB/ 6346.14-2015	C C20001280609	AC3008 (. . .)
ENEC	EN 60384-14:2013/A1:2016	ENEC-03177	AC3008 (. . .)
KC	K60384-14	H 03034-21003A	AC2508 (. . .)

5. /P

5.1 /P D

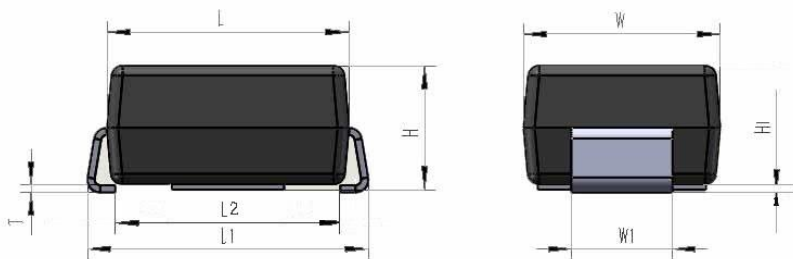

P		D		()	
L	4.3 0.1			3.5 0.3	
L1	5.0 0.1	L2		4.0 0.1	
H	2.2 0.1	1		1.8 0.05	
H1	0.1 0.05			0.13 0.02	

5.2 /P

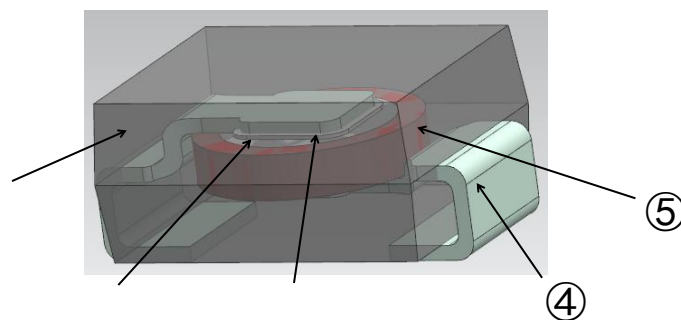

N .	P	M
①	C	(L948 -0) E (L948 -0)
②	E	/C
③		-P -A -P -A
④	L P	
⑤	D	C

SMD- 2

SMD 2 . .

/N -3-082

/D 2021-11-15

/E 52 D 2

 TRX 专注电容器廿年	SMD- 2			
	SMD 2 . .			
	/N	-3-082	/D	2021-11-15
	/E	A1	/P	P 9 18

6.2 /F

280 °
280°C

30 °
30

200 °
200

P 200

180 °
180

P 180

6.3 / I
PCB/P B

PCB/P B,

400
- 400

50
50

5
5

7. /P

NO	I		
1	A	N L L	
2	D	5.1 5.1	

 TRX 专注电容器廿年	SMD- 2			
	SMD 2 . .			
	/N	-3-082	/D	2021-11-15
/E	A1	/P	P 10 18	

NO	I															
3	8	B L B	N	/ : 2600 AC / : 50/60H / : 60 / : 5 A												
4	C		K: 10% M: 20%	/ : 25 3 /H : 55 30% H 8 : 1.0 0.2 /F : C I(L): 1 0.2MH C II(5P, 5 , 8): 1 0.2KH												
5	D.F.		L: 1.0% 5P: 2.5% 5 : 2.5% 8 : 2.5%	/ : 25 3 /H : 55 30% H 8 : 1.0 0.2 /F : C I(L): 1 0.2MH C II(5P, 5 , 8): 1 0.2KH												
6	CC		L:+140 -1000(/) 5P: 10% 5 : +22% -56% 8 : +22% -82%	/ CC: 2 <table border="1" style="margin-left: auto; margin-right: auto;"> <tr> <td></td> <td>1</td> <td>2</td> <td>3</td> <td>4</td> <td>5</td> </tr> <tr> <td>()</td> <td>+20</td> <td>-25</td> <td>+20</td> <td>+85</td> <td>+20</td> </tr> </table> $\Delta = C - C_0 / C_0$ C : 2,4 C ₀ : 3		1	2	3	4	5	()	+20	-25	+20	+85	+20
	1	2	3	4	5											
()	+20	-25	+20	+85	+20											
7	I .	B B	6000M MIN 6000M MIN	DC500 508 60± 5 1M DC500 508 60 5 1M												

 TRX 专注电容器廿年	SMD- 2				
	SMD 2 . .				
	/N	-3-082	/D	2021-11-15	
		/E	A1	/P	P 11 18

NO	I			
8				150 180 C 90 30 P 150 180 C 90 30 . / : 230 C-260 C / : 60± 15 . / :4 15--35 45--75% H 24 2 L 15-35 , 45-75% H 24 2 , .
			NO.3 P NO.3	
	C		L:± 10% 5P:± 10% 5 :± 20% 8 :± 20%	
	D.F.		L: 1.0% 5P: 2.5% 5 : 2.5% 8 : 2.5%	
	I .		NO.7 P NO.7	
9				(JI K 5902) (JI K 8101) (25%) () I (90%) 3 5902) (25% (JI K 8101) (JI K) . () I 2 0.5 2 0.5 . : 245 10 C
10			N	
			NO.3 P NO.3	: +125 3
	C		L:± 10% 5P: 10% 5 : 20% 8 : 20%	: -40 3 / :5
	D.F.		L: 1.0% 5P: 2.5% 5 : 2.5% 8 : 2.5%	30 25 3 24 2
	I .		NO.7 P NO.7	C 24 2 25 3 .

SMD- 2
SMD

SMD- 2
SMD 2 . .



/N

-3-082

/D

2021-11-15

/E

A1

/P

P 13 18

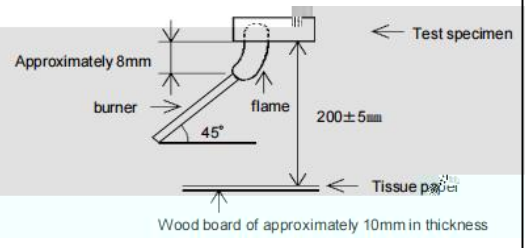
NO	I		
14	I	<p>N</p> <hr/> <p>I</p> <hr/> <p>24 3</p> <p>I 24 3</p> <hr/> <p>I</p>	<p>P : 5.0K8</p> <p>I : 10</p> <p>I : 24</p>
15	P	<p>30</p> <p>30 .</p>	<p>30</p> <p>. E</p> <p>: 30 .</p> <p>/L : 12 1</p> <p>35</p> <p>G : L 35 .</p> <p>/I : 0.5 0.1</p> <p>/O : 0.9 .</p> <p>95%</p> <p>G : B 95% .</p> 

 TRX 专注电容器廿年	SMD- 2 SMD 2 . .			
	/N	-3-082	/D	2021-11-15
	/E	A1	/P	P 14 18

NO	I		
16	C	N NO.3 NO.7 P N .3 N .7	$30 \pm 5\%$ $70 \pm 5\%$ $30 \pm 5\%$ $70 \pm 5\%$ / 23.5 5 ± 0.5 $5.0.5$ / 8
17			$30 \pm 5\%$ $70 \pm 5\%$ $30 \pm 5\%$ $70 \pm 5\%$ / 23.5 5 ± 0.5 10 $5.0.5$ 10

8. /C

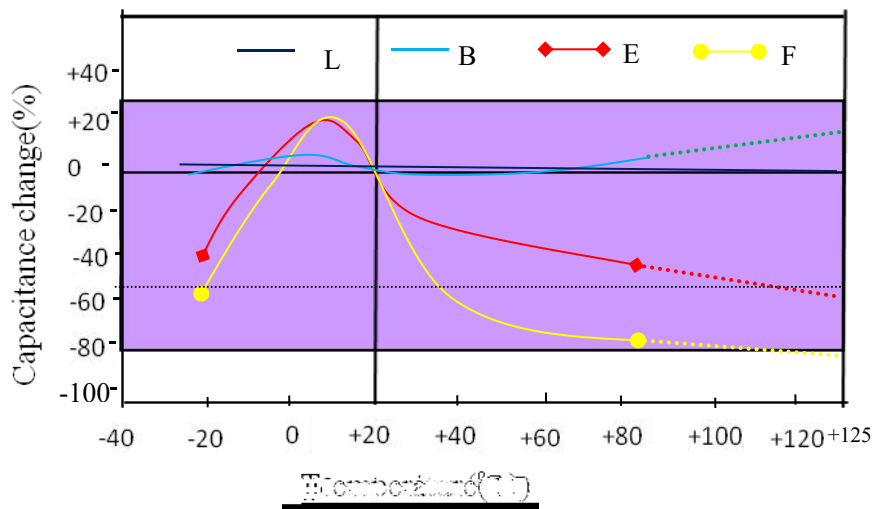

 TRX 专注电容器廿年	SMD- 2			
	SMD 2 . .			
	/N	-3-082	/D	2021-11-15
	/E	A1	/P	P 16 18

11. /P P

11.1 /D

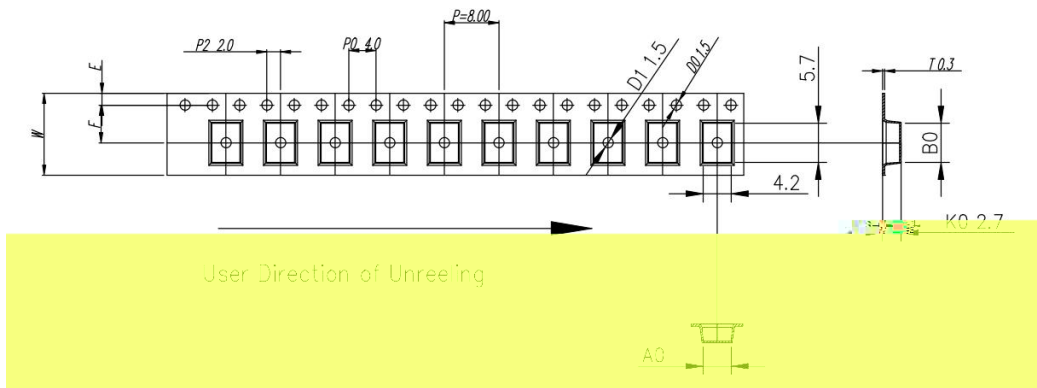

ITEM	W	A0	B0	K1	K0	P	F	E	D0	D1	P0	P2	T
DIM	12.0	$4.30^{+0.10/-0.30}$	$5.70^{+0.10/-0.10}$	--	$2.70^{+0.10/-0.10}$	8.00	$5.50^{+0.10/-0.10}$	1.75	$1.5^{+0.10/-0.10}$	$1.5^{+0.10/-0.10}$	4.0	2.0	0.30
ALTERNATE													

11.2 /D

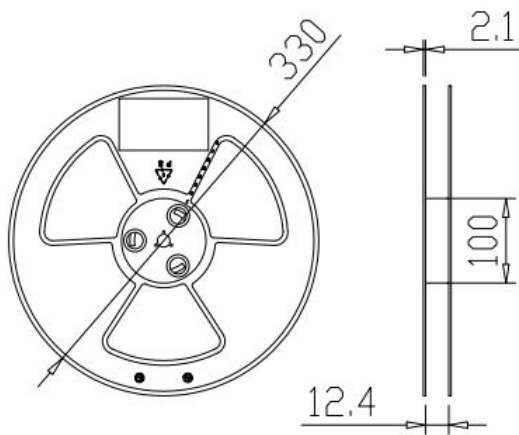

EEL	EEL I E
3000	13



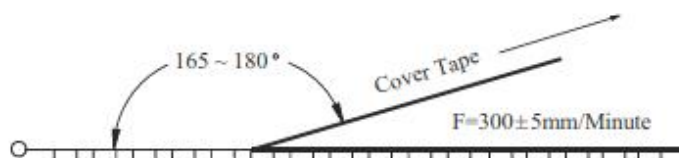

11.3 /P

Item	Data	Remark
Cover tape adhesion	10 ~ 100g	Carrier tape and cover tape open angle 165 ~ 180° F=300±5mm/minute



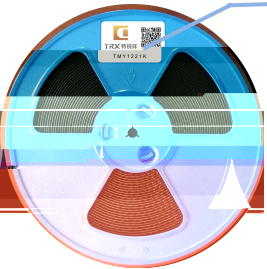

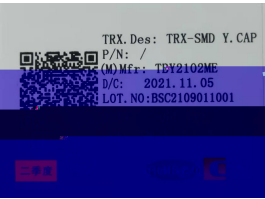

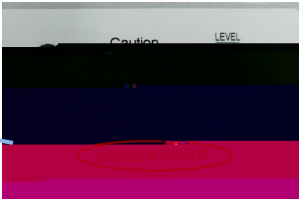
 TRX 专注电容器廿年	SMD- 2			
	SMD 2 . .			
	/N	-3-082	/D	2021-11-15
/E	A1	/P	P 17 18	



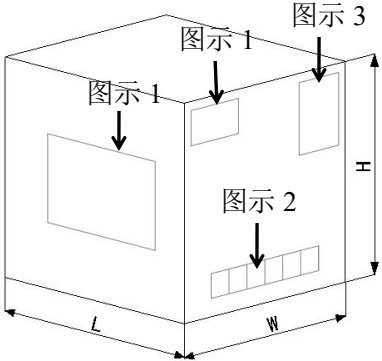

11.4 /P P

/ -	 标签/L  料号 TRX 特锐祥 TBY2102ME		/I
/ : 13 3.0KPC /	  		.D
/P	/L	/H	P/N
			M
			D/C
			L .N
			PEC

/O -

			
图示 1/F 1	图示 2/F 2	图示 3/F 3	
D ()			O B
L	H	45KPC	10.0KG
355	358	294	

/P :

			
/O B	15 / /15 /B	(/ /) P (L/ /H) 1100*1100*90	(/ /) (L/ /H) 1100*1100*1600

1. " 5" 5 2. PALLE & APPING
 3.50 R :1. 5 4. / ' 5 ; 2. P & -
 ; 3.50 ; 4. N

	SMD- 2			
	SMD 2 . .			
	/N	-3-082	/D	2021-11-15
	/E	A1	/P	P 18 18

12. /A

①.

A

②.

.
PCB
PCB
C CB

PCB